



—

# **BRIGHT STONES**

—

# STONE



## APPLICATION



The luminous stones hide a perfectly functional LED source inside, but invisible from the outside. The effect is similar to that of optical fiber and the brightness filters through the surface as if it were translucent to diffuse into the environment. The luminous stones are made using a particular polymeric compound capable of reproducing the surface of the flooring



# STONE

## SPECIFICATIONS



Installation:  
Ground recessed

- The rated flux values refer to source LED at Ts85°C / ta25°C
- The Power/Flux in the table refer to maximum installable value
- Dimmable version available on request only with remote driver
- The device is supplied with a long cable 1m 2x0.5mm<sup>2</sup>
- **IP68 connector available on request**
- **Walkable for pedestrian paths. (Max load 500Kg) and driveways (Max load 5000Kg)**
- **12V REMOTE DRIVER must be ordered separately \*\*Pag.440**

## DIMENSIONS

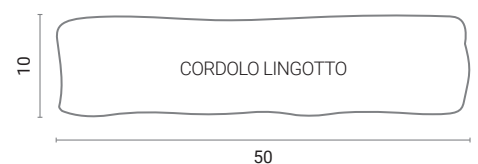
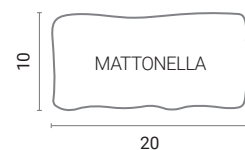
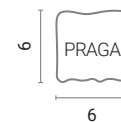
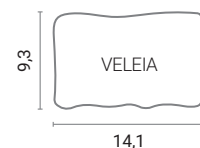
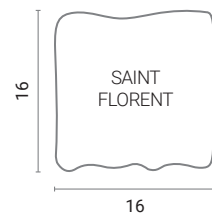
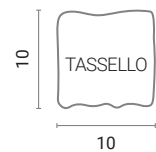

TASSELLO LED PL.00.1



SAINT FLORENT LED PL.00.2



VELEIA LED PL.00.3



PRAGA LED PL.00.4



MATTONELLA LED PL.00.5



CORDOLO LINGOTTO LED PL.00.6



## SINGLE STONE WITH 12V REMOTE DRIVER

COD.	Model	System	CRI	Power	Kg
PL.00.1	TASSELLO LED 100x100x60 Tumbled single layer Colors: Cotto	140 lm	70	3W 220-240Vac 50/60Hz	0.82
PL.00.2	SAINT FLORENT LED 160x160x60 Double layer impression Colors: Jasper green / Luserna	140 lm	70	9W 220-240Vac 50/60Hz	1.90
PL.00.3	VELEIA LED 93x141x60 Tumbled single layer Colors: Mustard	140 lm	70	7.5W 220-240Vac 50/60Hz	0.87
PL.00.4	PRAGA LED 60x60x60 Tumbled single layer Colors: Ice flamed	140 lm	70	3W 220-240Vac 50/60Hz	0.35
PL.00.5	MATTONELLA LED 200x100x60 Tumbled single layer Colors: Cotto	140 lm	70	12W 220-240Vac 50/60Hz	2.00
PL.00.6	CORDOLO LINGOTTO 500x100x100 Monolayer Colors: White	140 lm	70	25W 220-240Vac 50/60Hz	8.00

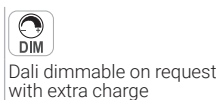
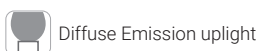

# POETARI

## SPECIFICATIONS



Installation:  
Ground recessed

- The rated flux values refer to source LED at Ts85°C / ta25°C
- The Power/Flux in the table refer to maximum installable value
- Dimmable version available on request only with remote driver
- The device is supplied with a long cable 1m 2x0.5mm<sup>2</sup>
- **IP68 connector available on request**
- **Walkable for pedestrian paths. (Max load 500Kg) and driveways (Max load 5000Kg)**
- **Available in different formats of letters and numbers**
- **12V REMOTE DRIVER must be ordered separately \*\*Pag.440**

## POETARI LED PL.00.7



### SINGLE STONE WITH 12V REMOTE DRIVER

COD.	Model	System	CRI	Power	Kg
PL.00.7	POETARI LED H=70 Monolayer Colors: White	60 lm	70	3W 220-240Vac 50/60Hz	0.78



Dali dimmable on request with extra charge

## LETTERS

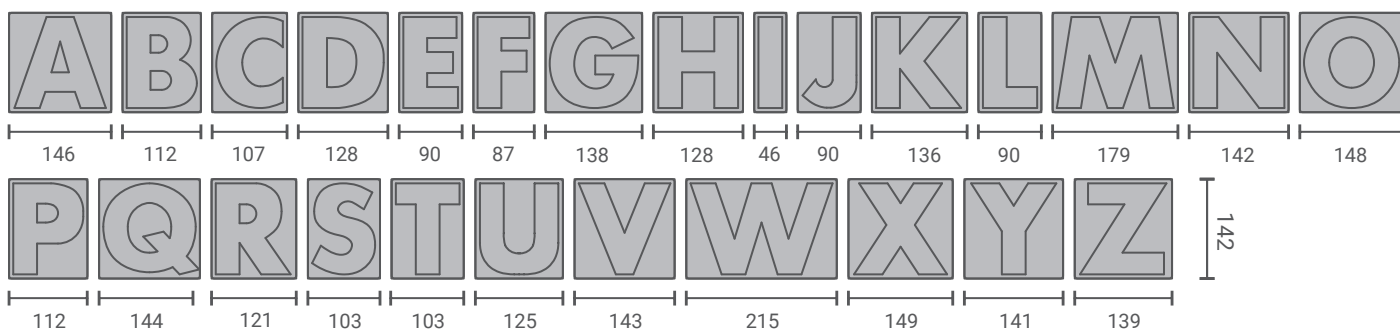

## NUMBERS

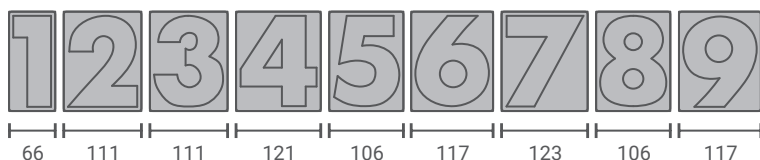

## PUNCTUATION

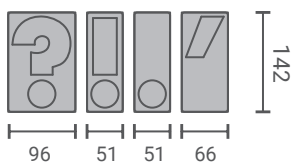

BRIGHT STONES

# POETARI

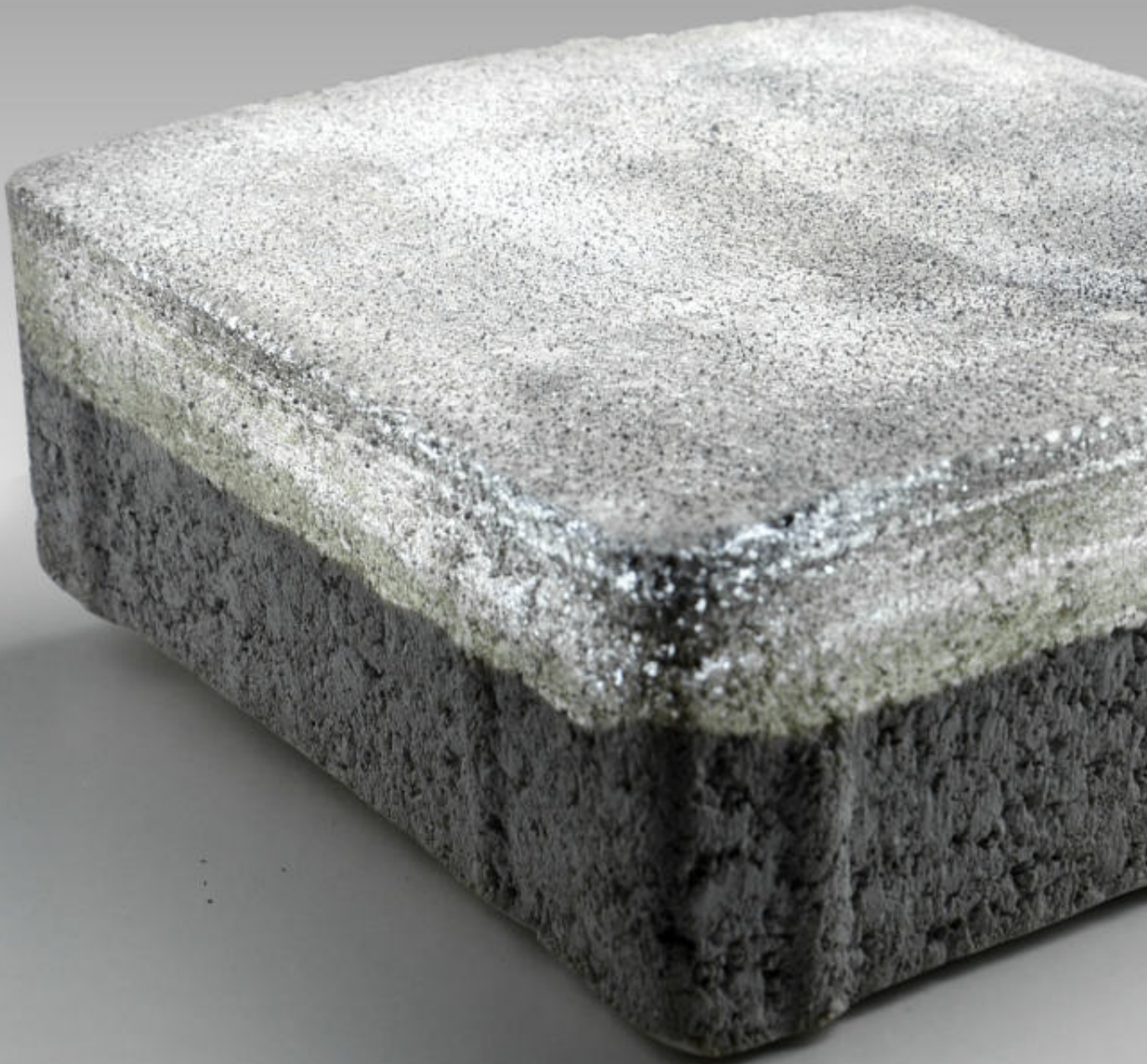

# SAFETY CROSSING

## SPECIFICATIONS



Installation:  
Ground recessed

- The rated flux values refer to source LED at  $T_s 85^{\circ}\text{C}$  /  $t_a 25^{\circ}\text{C}$
- The Power/Flux in the table refer to maximum installable value
- Dimmable version available on request only with remote driver
- The device is supplied with a long cable 1m  $2 \times 0.5 \text{mm}^2$
- **IP68 connector available on request**
- **Walkable for pedestrian paths. (Max load 500Kg) and driveways (Max load 5000Kg)**
- **The installation of the product is foreseen fixed with glue, mortar, sand or, to facilitate any maintenance operations, it is possible to use a stainless steel formwork. (On request)**
- **12V REMOTE DRIVER must be ordered separately\*\***

## DIMENSIONS

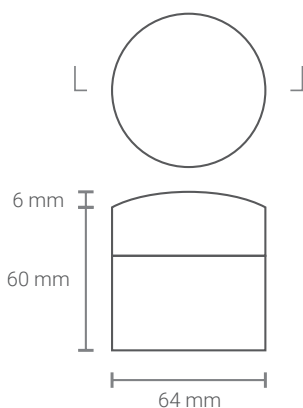

SAFETY CROSSING LED

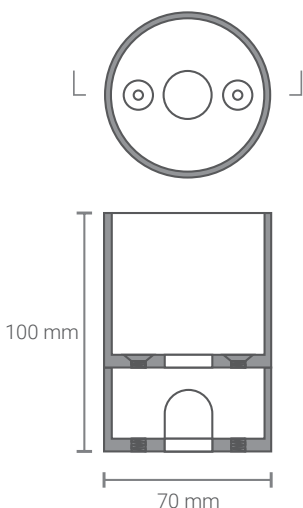

STEEL FRAME FOR BUILT-IN

## SAFETY CROSSING LED



### SINGLE STONE WITH 12V REMOTE DRIVER

COD.	Model	System	CRI	Power	Kg
PL.00.8	SAFETY CROSSING LED Ø64x66 Smooth convex White color	30 lm	70	1W 220-240Vac 50/60Hz	0.30



Diffuse Emission uplight



Dali dimmable on request with extra charge

## PHOTOMETRICS DATA

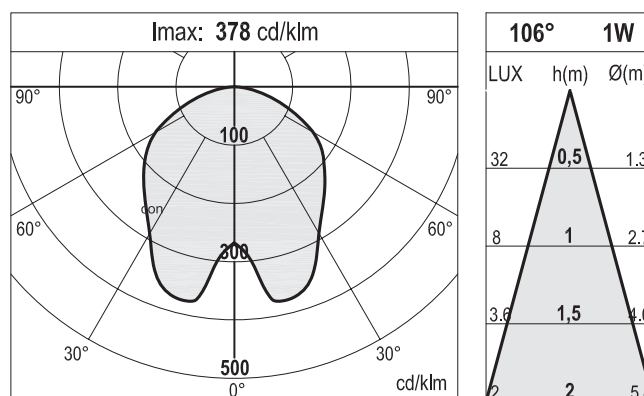

ELECTRONIC ACCESSORIES FOR ALL BRIGHT STONES  
\*\* 12V REMOTE DRIVER TO BE ORDERED SEPARATELY



### 12V REMOTE DRIVER

COD.	IP	Power	CL
122477	68	70W	III

BRIGHT STONES

# SAFETY CROSSING

